

EAGLE TECHNICAL BULLETIN

REF. TCCA STC: SH14-47
REF. FAA STC SR03496NY

Eagle Technical Bulletin Number: **TB-E407-789-4**

Purpose: To repair corrosion under the transmission mounts and under the fwd firewall

Eligible Serial Numbers: 53494, 53599, 53591, 53522. \triangle D

Compliance: During the incorporation of STC SH14-47/SR03496NY

Description:

A) Transmission Mount Doubler

It is acceptable to replace the Bell -1 Doubler, -2 Doubler and -3 Filler installed per Repair number 09RL-073 as well as 0789-03-001-1 Doubler Large and 0789-03-005-1 Doubler installed per TC STC SH14-47 (FAA STC SR03496NY) with the 0789-03-210-1/-3 Doubler Large and 0789-03-211-1 Packer or 0789-03-002-1 Packer as applicable.

B) FWD Firewall Doubler

Repair corrosion under the FWD firewall by cutting out corroded area and blending smooth. It is acceptable to replace Bell p/n 407-030-401-177 Skin with 0789-03-212-1 Repair Doubler.

Compliance with this Technical Bulletin requires the parts listed in Table 1 below.

Table 1 - Parts List

QTY -011	QTY -013	QTY -015	PART NUMBER	DESCRIPTION
X			TB-E407-789-4-011	STRUCTURAL REPAIR KIT (S/N 53494)
	X		TB-E407-789-4-013	STRUCTURAL REPAIR KIT (S/N 53599)
		X	TB-E407-789-4-015	STRUCTURAL REPAIR KIT (S/N 53591 / 53522) \triangle D
1	1		0789-03-210-1	DOUBLER, LARGE
		1	0789-03-210-3	DOUBLER, LARGE (LH ONLY)
1	1		0789-03-211-1	PACKER
1			0789-03-212-1	REPAIR DOUBLER
15			140-001-1	WASHER
15			MS20615-4M	RIVET
A/R	A/R	A/R	PER 0789-01-101 / TB 407-13-104	RIVETS PER DWG 0789-01-101 & TB 407-13-104

Weight and Balance:

Weight and Balance change to the aircraft is accomplished as part of STC SH14-47 / SR03496NY.

CANADA
DEPARTMENT OF TRANSPORT
AIRCRAFT CERTIFICATION
BRANCH
DAO # 01-O-01

APPROVED

BY: 
D. SHEPHERD (DE # 02)

DATE: 18.11.23
CERT. NO.: SH14-47
ISSUE NO.: 1

APPROVED

D	ADDED ELIGIBLE SERIAL # 53522	PM	18.11.23
C	ADDED TB-E407-789-4-013/-015	WK	18.07.11
B	ADDED ELIGIBLE SERIAL # 53599	PM	17.09.26
A	NEW ISSUE	VS	16.05.05
REV.	DESCRIPTION	BY	DATE
DESIGN	VS	EAGLE COPTERS LTD CALGARY, ALBERTA, CANADA	
DRAWN	PM		
CHECKED	WK	DRAWING NO.	REV. D
MFG. APPR.	JD	TB-E407-789-4	SHEET 1 OF 8
APPROVED	WK	TITLE	SCALE
DE APPR.	DS	STRUCTURAL REPAIR	NTS
DATE	18.11.23	<small>COPYRIGHT © 2018 BY EAGLE COPTERS LTD. THIS DOCUMENT IS PRIVATE AND CONFIDENTIAL AND IS SUPPLIED ON THE EXPRESS CONDITION THAT IT IS NOT TO BE USED FOR ANY PURPOSE OR COPIED OR COMMUNICATED TO ANY OTHER PERSON WITHOUT WRITTEN PERMISSION FROM EAGLE COPTERS LTD.</small>	

Procedure:

A) Transmission Mount Doubler

(0789-03-210-1 Applicable to S/N 53494 and 53599, 0789-03-210-3 Applicable to S/N 53591 and 53522.) \triangle

1. On S/N 53494, gain access to the area repaired by 09RL-073 Repair. Remove -1 Doubler, -2 Doubler and -3 Filler.
2. Remove corrosion completely from corroded area using instructions detailed in Bell TB 407-13-104 and BHT-ALL-SRM. Blend out damaged areas using a 10:1 length to depth ratio and ensure a smooth transition.
3. On S/N 53494 and 53599, transfer drill 0789-03-210-1 Doubler Large and 0789-03-211-1 Packer in place of p/n 0789-03-001-1 Doubler Large, p/n 0789-03-002-1 Packer and p/n 0789-03-005-1 Doubler per 0789-01-101 Doubler Installation Brake Disk, 0789-01-102 Doubler Installation and TB 407-13-104. On S/N 53494 only, transfer drill also per Bell Repair 09RL-073. Refer to Figure 2 and Figure 3.

\triangle 4. On S/N 53591 and 53522, transfer drill 0789-03-210-3 Doubler Large in place of p/n 0789-03-001-1 Doubler Large per Installation Drawing 0789-01-101 Doubler Installation and TB 407-13-104. Install the 0789-03-005-1 Doubler at STA 144.63 per Installation Drawing 0789-01-102 Doubler Installation and TB 407-13-104. Continue to use 0789-03-002-1 Packer. Refer to Figure 4.

5. Fill blended and cutout areas with bonding adhesive per Bell Spec 299-947-100, Type II, Class 3.
6. Allow to cure at room temperature for 24 hours.
7. Sand adhesive flush with AFT doubler (Bell p/n 407-030-401-153) and clean for bonding.
8. Locate and position the 0789-03-210-1/-3 Doubler Large and 0789-03-211-1 or 0789-03-002-1 Packer as applicable, using bonding adhesive per Bell Spec 299-947-100, Type II, Class 3.
9. Install all rivets while adhesive is still wet in previous transfer drilled holes per Installation Drawing 0789-01-101 Doubler Installation and TB 407-13-104.
10. Remove excess adhesive squeeze-out.
11. Allow to cure at room temperature for 24 hours applying a pressure of 0.5 to 1.0 psi to repair area.
12. Inspect for voids and unbonded areas. Voids shall not exceed 10% of total bonded area. No one void shall exceed 0.25 square inch in area.
13. Prime all bare metal surfaces using Epoxy Polyamide Primer, per MIL-P-23377. Seal all edges of doubler using sealant per MIL-S-81733, Type II. Allow to dry. Re-prime sealant.

APPROVED

DESIGN	VS	EAGLE COPTERS LTD CALGARY, ALBERTA, CANADA	
DRAWN	PM		
CHECKED	WK	DRAWING NO.	REV. D
MFG. APPR.	JD	TB-E407-789-4	SHEET 2 OF 8
APPROVED	WK	TITLE	SCALE
DE APPR.	DS	STRUCTURAL REPAIR	NTS
DATE	18.11.23	<small>COPYRIGHT © 2016 BY EAGLE COPTERS LTD. THIS DOCUMENT IS PRIVATE AND CONFIDENTIAL AND IS SUPPLIED ON THE EXPRESS CONDITION THAT IT IS NOT TO BE USED FOR ANY PURPOSE OR COPIED OR COMMUNICATED TO ANY OTHER PERSON WITHOUT WRITTEN PERMISSION FROM EAGLE COPTERS LTD.</small>	

B) FWD Firewall Doubler
(Applicable to S/N 53494)

1. Gain access to the Bell 407-030-401-177 Skin and remove.
2. Remove corrosion completely from roof panel assy using instructions detailed in BHT-ALL-SRM. Blend out damaged areas using a 10:1 length to depth ratio and ensure smooth transistions.
3. Cut out/drill to remove damaged portions per Figure 1.
4. Alodine and prime blended areas per ICA-E407-789.
5. Apply primer to the underside of the 0789-03-212-1 Repair Doubler per ICA-E407-789.
6. Transfer drill the 0789-03-212-1 Repair Doubler from the cabin roof in place of 407-030-401-177 Skin. Transfer drill to the roof assembly from the 0789-03-212-1 Repair Doubler to the cabin roof using the FWD two rows of holes on the 0789-03-212-1 Repair Doubler per Figure 2. Take care not to damage underlying structures during drilling operation. Do not drill through inner skin except outside core area.
7. Locate and position the Repair Doubler using Proseal PS890 B2.
8. Install 0789-03-212-1 Repair Doubler in place of the Bell 407-030-401-177 Skin. Install the FWD two rows of holes on the 0789-03-212-1 Repair Doubler using MS20615-4M(X) Rivets and 140-001-1 Washers on the under side of the roof assembly per Figure 2.

C) Documentation

1. Notify Eagle Copters that this Technical Bulletin has been accomplished by filling the attached form (Sheet 8) and emailing it to Eagle Copters.
2. Make entry into aircraft technical reports to indicate TB-E407-789-4 has been completed.

APPROVED

DESIGN	VS	EAGLE COPTERS LTD CALGARY, ALBERTA, CANADA	
DRAWN	PM		
CHECKED	WK	DRAWING NO.	REV. D
MFG. APPR.	JD	TB-E407-789-4	SHEET 3 OF 8
APPROVED	WK	TITLE	SCALE
DE APPR.	DS 	STRUCTURAL REPAIR	NTS
DATE	18.11.23	<small>COPYRIGHT © 2016 BY EAGLE COPTERS LTD. THIS DOCUMENT IS PRIVATE AND CONFIDENTIAL AND IS SUPPLIED ON THE EXPRESS CONDITION THAT IT IS NOT TO BE USED FOR ANY PURPOSE OR COPIED OR COMMUNICATED TO ANY OTHER PERSON WITHOUT WRITTEN PERMISSION FROM EAGLE COPTERS LTD.</small>	

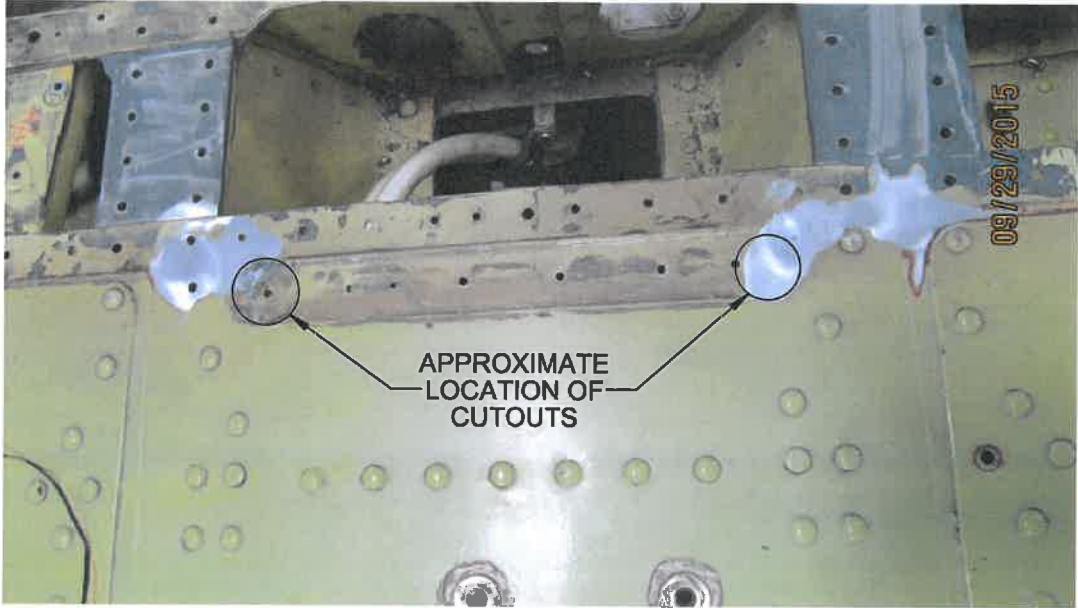

Figure 1 - Roof Assembly Corrosion Cutouts

APPROVED

DESIGN	VS	EAGLE COPTERS LTD CALGARY, ALBERTA, CANADA	DRAWING NO. TB-E407-789-4	REV. D
DRAWN	PM			SHEET 4 OF 8
CHECKED	WK	TITLE	SCALE	
MFG. APPR.	JD	STRUCTURAL REPAIR	NTS	
APPROVED	WK			
DE APPR.	DS			
DATE	18.11.23	<small>COPYRIGHT © 2016 BY EAGLE COPTERS LTD. THIS DOCUMENT IS PRIVATE AND CONFIDENTIAL AND IS SUPPLIED ON THE EXPRESS CONDITION THAT IT IS NOT TO BE USED FOR ANY PURPOSE OR COPIED OR COMMUNICATED TO ANY OTHER PERSON WITHOUT WRITTEN PERMISSION FROM EAGLE COPTERS LTD.</small>		

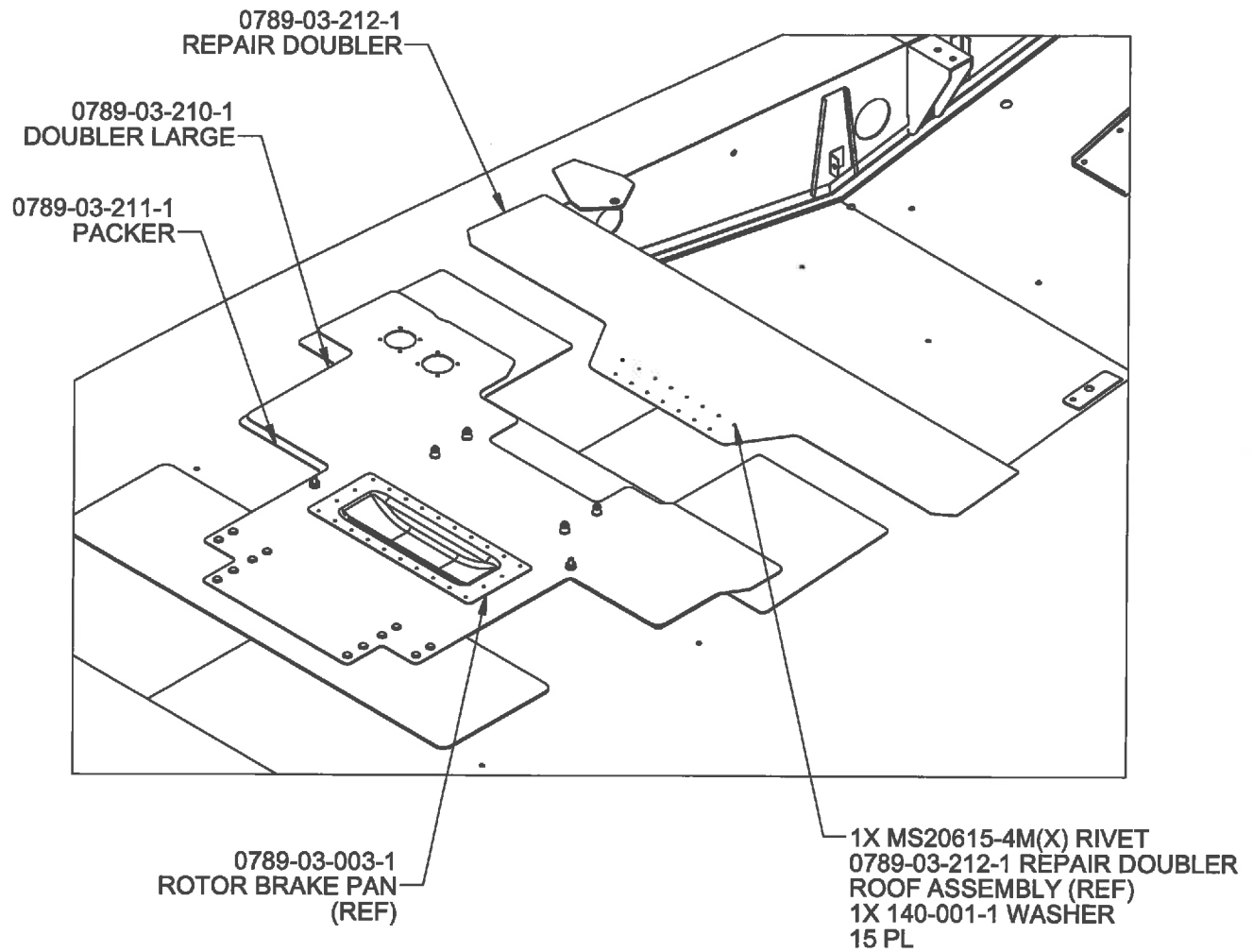

Figure 2 - Doubler Installation
(TB-E407-789-4-011 on S/N 53494)

APPROVED

DESIGN	VS	EAGLE COPTERS LTD CALGARY, ALBERTA, CANADA	
DRAWN	PM		
CHECKED	WK	DRAWING NO.	REV. D
MFG. APPR.	JD	TB-E407-789-4	SHEET 5 OF 8
APPROVED	WK	TITLE	SCALE
DE APPR.	DS	STRUCTURAL REPAIR	NTS
DATE	18.11.23	<small>COPYRIGHT © 2016 BY EAGLE COPTERS LTD. THIS DOCUMENT IS PRIVATE AND CONFIDENTIAL AND IS SUPPLIED ON THE EXPRESS CONDITION THAT IT IS NOT TO BE USED FOR ANY PURPOSE OR COPIED OR COMMUNICATED TO ANY OTHER PERSON WITHOUT WRITTEN PERMISSION FROM EAGLE COPTERS LTD.</small>	

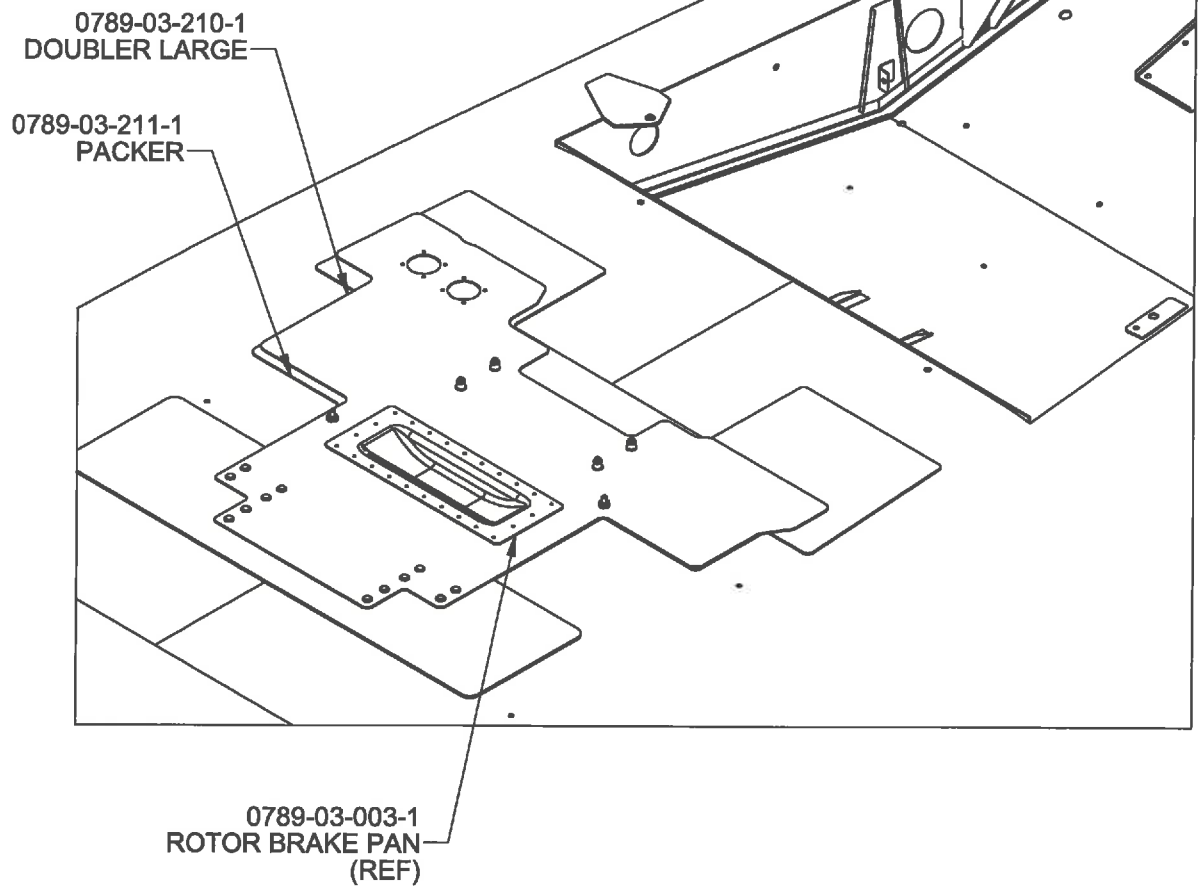

Figure 3 - Doubler Installation
 (TB-E407-789-4-013 on S/N 53599)

APPROVED

DESIGN	VS	EAGLE COPTERS LTD CALGARY, ALBERTA, CANADA	
DRAWN	PM		
CHECKED	WK	DRAWING NO.	REV. D
MFG. APPR.	JD	TB-E407-789-4	SHEET 6 OF 8
APPROVED	WK	TITLE	SCALE
DE APPR.	DS	STRUCTURAL REPAIR	NTS
DATE	18.11.23	<small>COPYRIGHT © 2016 BY EAGLE COPTERS LTD. THIS DOCUMENT IS PRIVATE AND CONFIDENTIAL AND IS SUPPLIED ON THE EXPRESS CONDITION THAT IT IS NOT TO BE USED FOR ANY PURPOSE OR COPIED OR COMMUNICATED TO ANY OTHER PERSON WITHOUT WRITTEN PERMISSION FROM EAGLE COPTERS LTD.</small>	

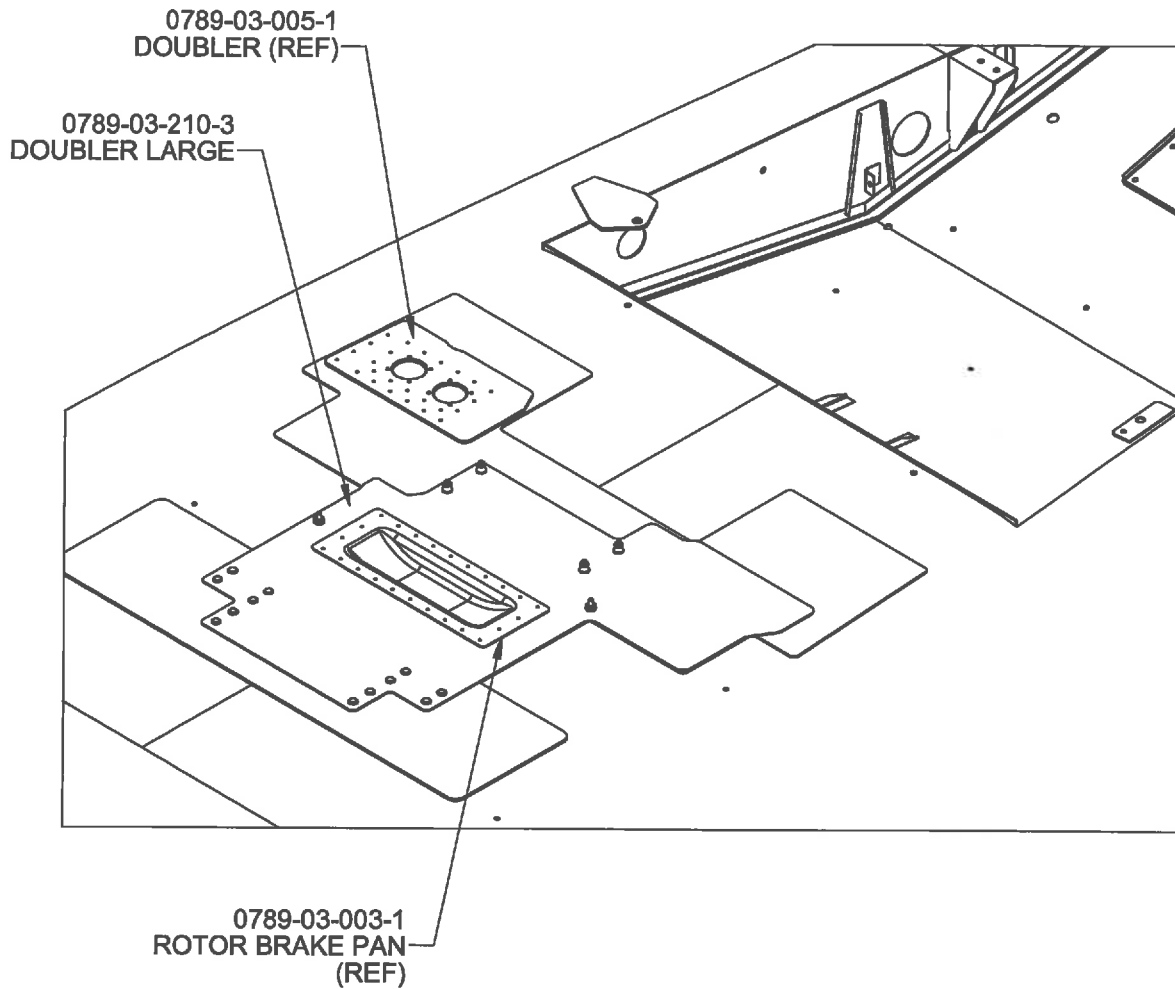

Figure 4 - Doubler Installation
 (TB-E407-789-4-015 on S/N 53591, 53522)



APPROVED

DESIGN	VS	EAGLE COPTERS LTD CALGARY, ALBERTA, CANADA	REV. D
DRAWN	PM		
CHECKED	WK	DRAWING NO.	SHEET 7 OF 8
MFG. APPR.	JD	TB-E407-789-4	
APPROVED	WK	TITLE	SCALE
DE APPR.	DS	STRUCTURAL REPAIR	NTS
DATE	18.11.23	<small>COPYRIGHT © 2016 BY EAGLE COPTERS LTD. THIS DOCUMENT IS PRIVATE AND CONFIDENTIAL AND IS SUPPLIED ON THE EXPRESS CONDITION THAT IT IS NOT TO BE USED FOR ANY PURPOSE OR COPIED OR COMMUNICATED TO ANY OTHER PERSON WITHOUT WRITTEN PERMISSION FROM EAGLE COPTERS LTD.</small>	

NOTIFY EAGLE COPTERS THAT THE TB-E407-789-4 HAS BEEN INCORPORATED INTO THE AIRCRAFT LISTED BELOW.

AIRCRAFT SERIAL NUMBER: _____

AIRCRAFT OWNER: _____

DATE TB-E407-789-4 WAS INCORPORATED ON THE ABOVE AIRCRAFT:

SIGNATURE OF PERSON RESPONSIBLE FOR ENTRY INTO AIRCRAFT TECHNICAL RECORD:

PRINT NAME OF PERSON RESPONSIBLE FOR ENTRY INTO AIRCRAFT TECHNICAL RECORD:

Email this page to: jdjorg@eaglecopters.com

APPROVED

DESIGN	VS	EAGLE COPTERS LTD	
DRAWN	PM	CALGARY, ALBERTA, CANADA	
CHECKED	WK	DRAWING NO.	REV. D
MFG. APPR.	JD	TB-E407-789-4	SHEET 8 OF 8
APPROVED	WK	TITLE	SCALE
DE APPR.	DS	STRUCTURAL REPAIR	NTS
DATE	18.11.23	COPYRIGHT © 2016 BY EAGLE COPTERS LTD. THIS DOCUMENT IS PRIVATE AND CONFIDENTIAL AND IS SUPPLIED ON THE EXPRESS CONDITION THAT IT IS NOT TO BE USED FOR ANY PURPOSE OR COPIED OR COMMUNICATED TO ANY OTHER PERSON WITHOUT WRITTEN PERMISSION FROM EAGLE COPTERS LTD.	